

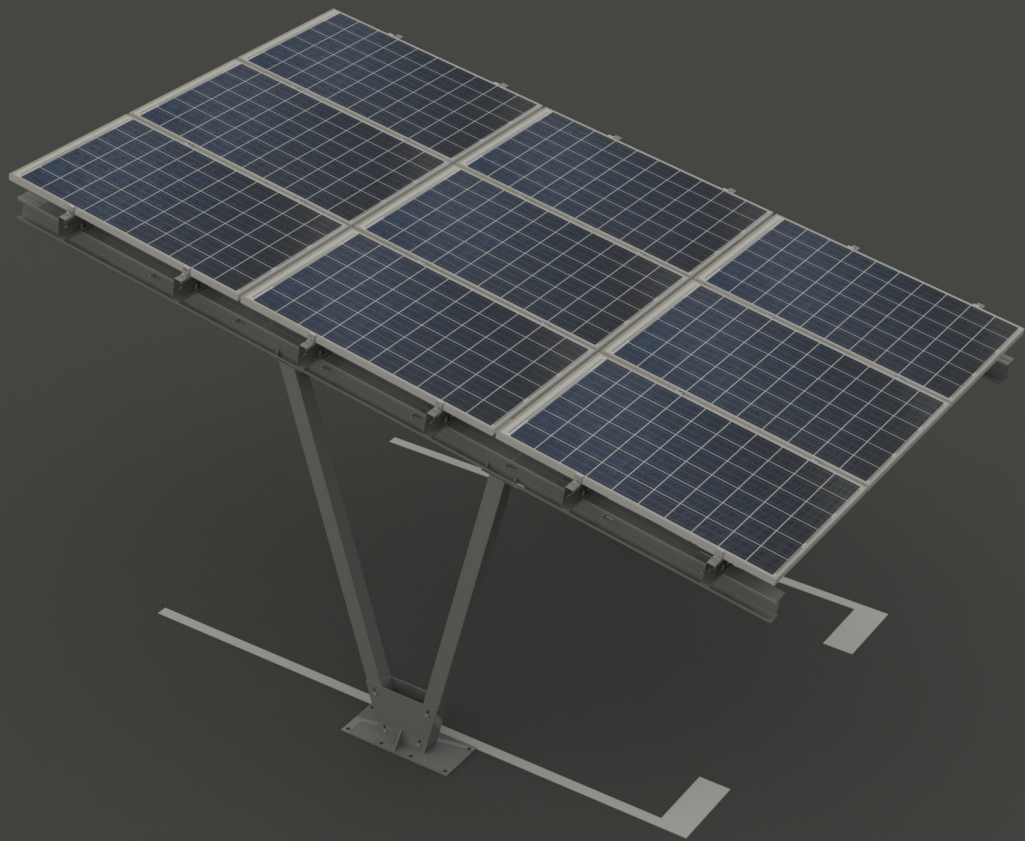

# CARPORT WUNC-1

Photovoltaic world for oneself.



With more than 25 years of experience in the manufacture of steel and aluminum components, Corab has become an important manufacturer of photovoltaic fastening systems. Constantly supplemented offerings include skewed, flat roof systems as well as standalone systems. Modern technological solutions allow the installation of panels on any roof air or soil type.

All products are subject to numerous and rigorous tests. The highest quality of workmanship guarantees the production in quality system **ISO 9001: 2008** and the sign **TÜV Rheinland Polska Monitoring +. Testing**

**WATT·U·NEED**  
www.wattuneed.com  
*By Solar-Tech*

SOLAR-TECH ENGINEERING SCRL  
Henripré 12, BE-4821 Andrimont  
VAT : BE0898 969 868 | CBC BE76 7320 2470 0695 | ING BE08 3630 3523 7413  
info@solar-tech.be | info@wattuneed.com | Phone : +32 87 45 00 34

# CARPORT WUNC-1

- Crown construction made of high quality steel with magnesium and aluminum coating
- Modular system - expandability for further parking spaces Quick and easy to assemble
- High static strength
- Tilt angle of 10 ° panels
- Very high corrosion resistance to corrosion
- Self-regenerating crown coating
- No electro corrosion effect

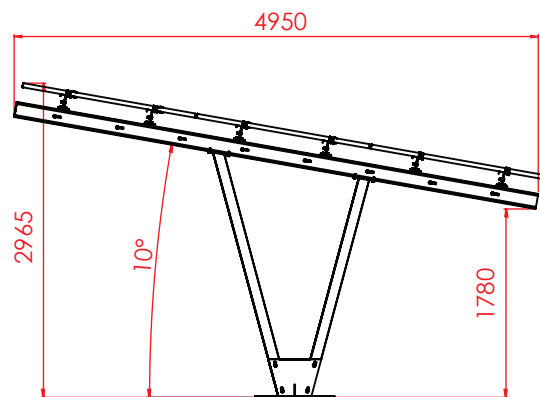
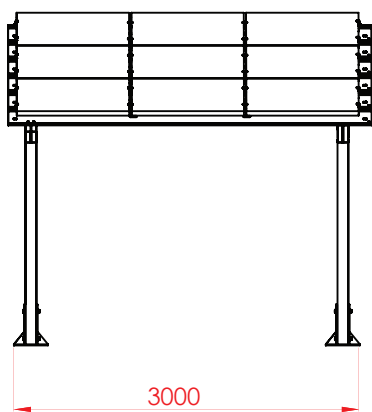

## TECHNICAL SPECIFICATIONS

- System material: high quality steel with special anti-corrosion coating, hot-dip galvanized steel
- Orientation panels: vertical, 3 rows
- Tilt angle of panels: 10 °
- System weight (9 modules): 398 kg
- Index: WUNC-1

## EXAMPLE OF EXPANSION

